



US007352078B2

(12) **United States Patent**  
**Gehring**

(10) **Patent No.:** **US 7,352,078 B2**

(45) **Date of Patent:** **Apr. 1, 2008**

(54) **OFFSHORE POWER GENERATOR WITH CURRENT, WAVE OR ALTERNATIVE GENERATORS**

(76) Inventor: **Donald Hollis Gehring**, 14690 Old Conroe Rd., Conroe, TX (US) 77384

(\* ) Notice: Subject to any disclaimer, the term of this patent is extended or adjusted under 35 U.S.C. 154(b) by 0 days.

(21) Appl. No.: **11/194,969**

(22) Filed: **Aug. 2, 2005**

(65) **Prior Publication Data**

US 2006/0261597 A1 Nov. 23, 2006

**Related U.S. Application Data**

(63) Continuation-in-part of application No. 11/132,489, filed on May 19, 2005, and a continuation-in-part of application No. 11/142,145, filed on Jun. 1, 2005.

(51) **Int. Cl.**  
**F03B 13/00** (2006.01)

(52) **U.S. Cl.** ..... **290/54**

(58) **Field of Classification Search** ..... 290/54  
See application file for complete search history.

(56) **References Cited**

**U.S. PATENT DOCUMENTS**

3,209,156	A *	9/1965	Struble, Jr. ....	290/54
3,911,287	A *	10/1975	Neville ....	290/53
3,946,568	A	3/1976	Heien	
3,986,787	A *	10/1976	Mouton et al. ....	415/7
4,025,220	A	5/1977	Thompson et al.	
4,060,344	A *	11/1977	Ootsu ....	417/330
4,095,422	A *	6/1978	Kurakake ....	60/398

4,228,360	A *	10/1980	Navarro .....	290/43
4,335,319	A *	6/1982	Mettersheimer, Jr. ....	290/54
4,613,279	A *	9/1986	Corren et al. ....	415/121.2
4,781,522	A *	11/1988	Wolfram .....	415/1
4,789,302	A *	12/1988	Gruzling .....	415/221
5,188,484	A	2/1993	White	
5,440,176	A *	8/1995	Haining .....	290/54
5,549,445	A *	8/1996	Schremp .....	415/2.1
5,573,355	A	11/1996	Thomas	
5,808,368	A *	9/1998	Brown .....	290/53
6,139,224	A	10/2000	Michel et al.	
6,406,251	B1 *	6/2002	Vauthier .....	415/7
7,012,341	B2 *	3/2006	Matsubara .....	290/43
7,116,005	B2 *	10/2006	Corcoran, III .....	290/43
2005/0285407	A1 *	12/2005	Davis et al. ....	290/54

**FOREIGN PATENT DOCUMENTS**

DE	20008482	U1 *	9/2000
GB	2383978	A *	7/2003
GB	2416193	A *	1/2006
JP	61226572	A *	10/1986
JP	2002303454	A *	10/2002
WO	WO 2004085845	A1 *	10/2004

\* cited by examiner

*Primary Examiner*—Joseph Waks  
(74) *Attorney, Agent, or Firm*—Bracewell & Giuliani LLP

(57) **ABSTRACT**

An offshore power generator includes an offshore platform. Current, wind, wave and other renewable energy generators are mounted to the offshore platform. Each current generator has a shroud enclosing a set of blades. A hub member is located within the shroud and extends in an upstream direction from the blades. The flow area between the interior of the shroud and the hub member converges from the shroud inlet to the blades.

**2 Claims, 16 Drawing Sheets**

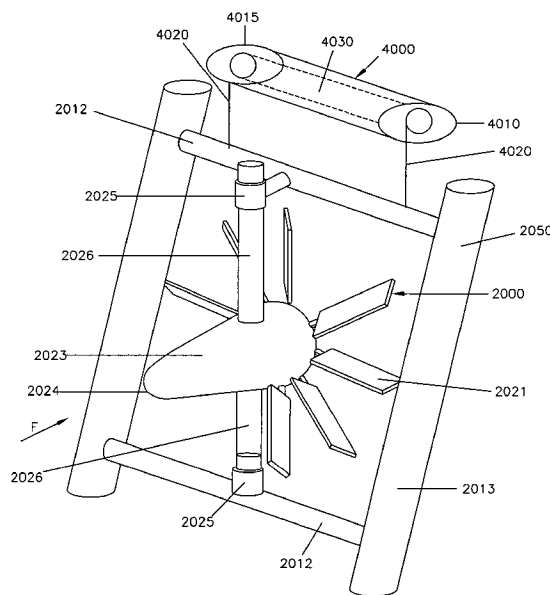

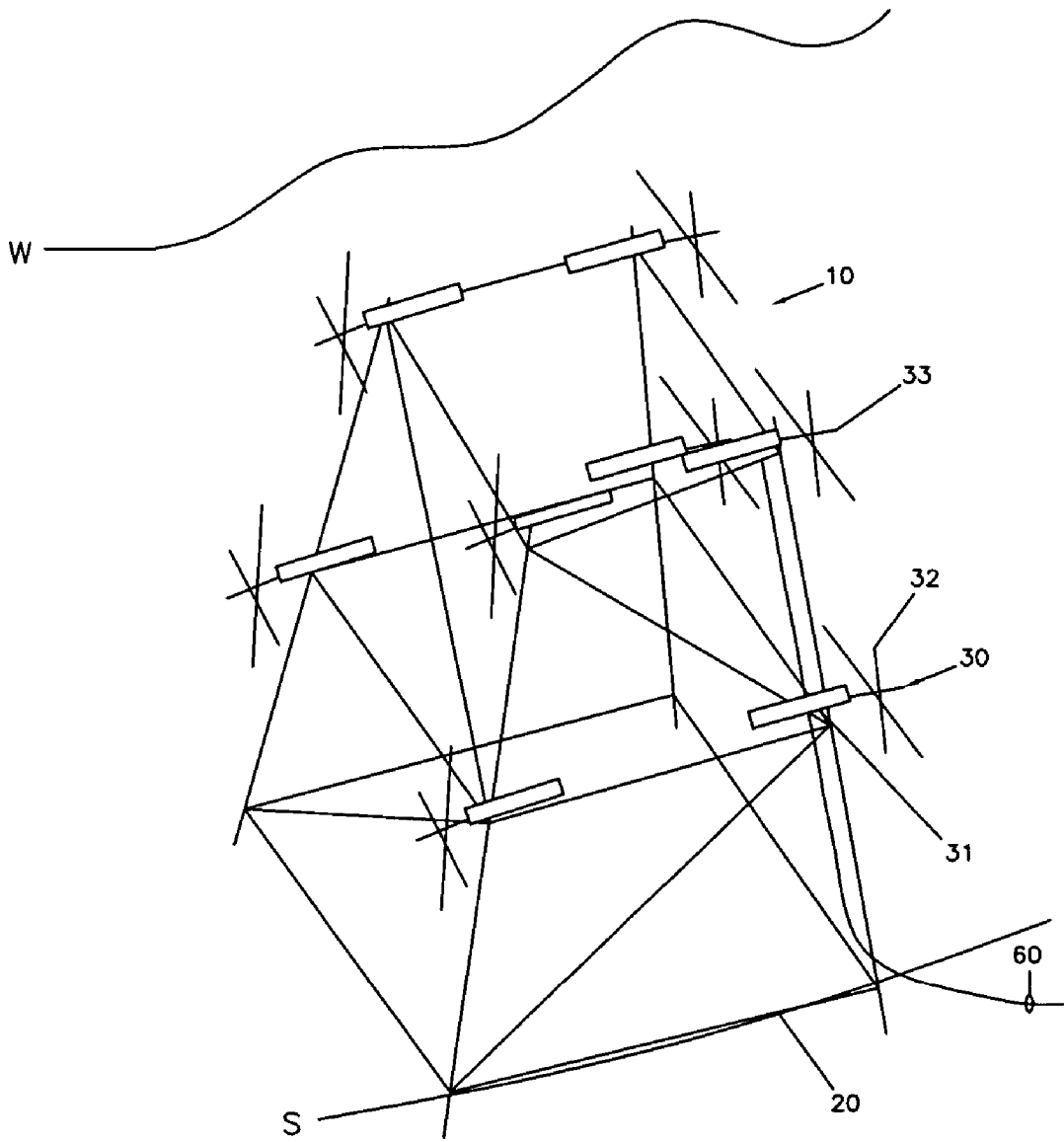

Figure 1

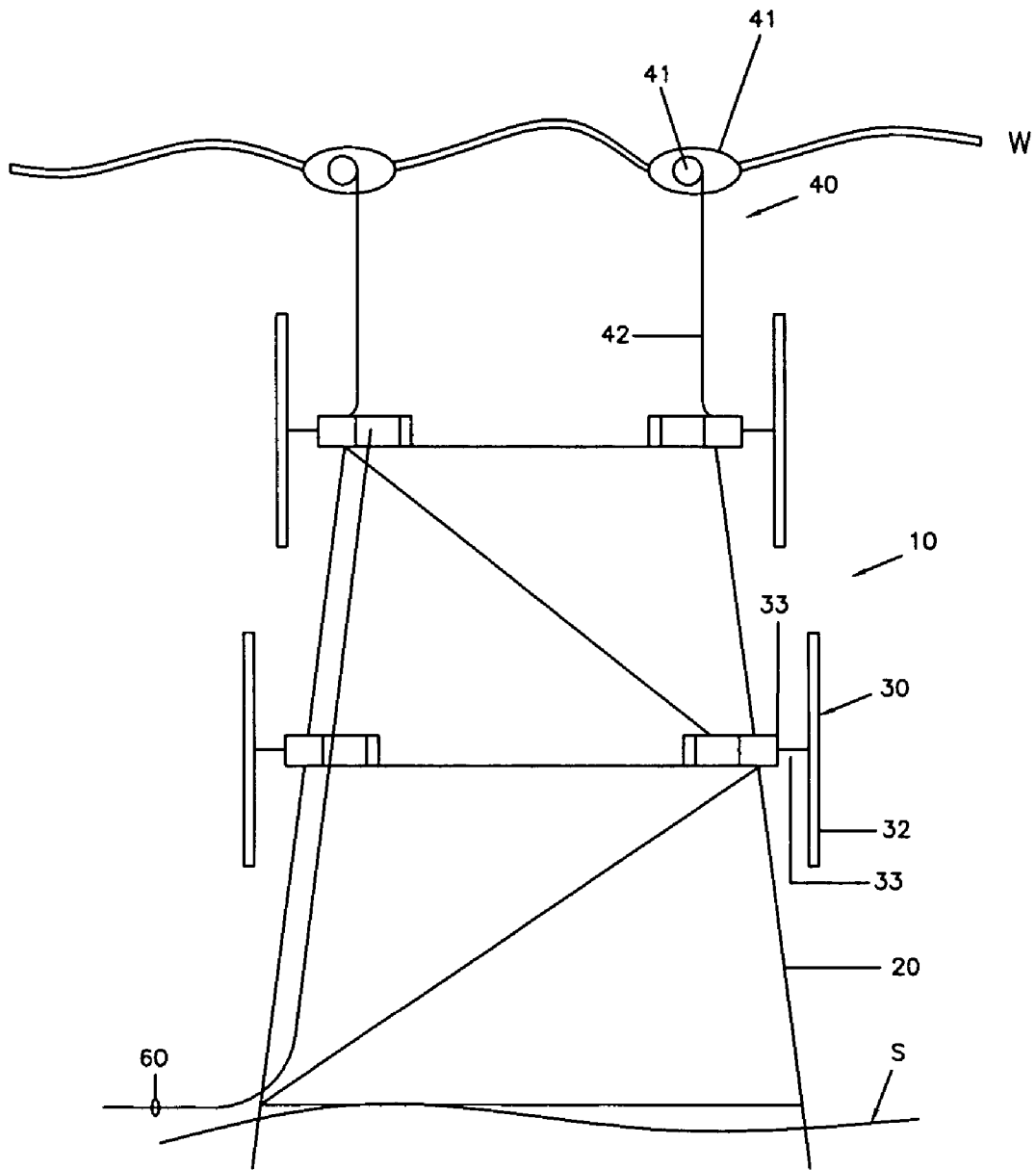

Figure 2

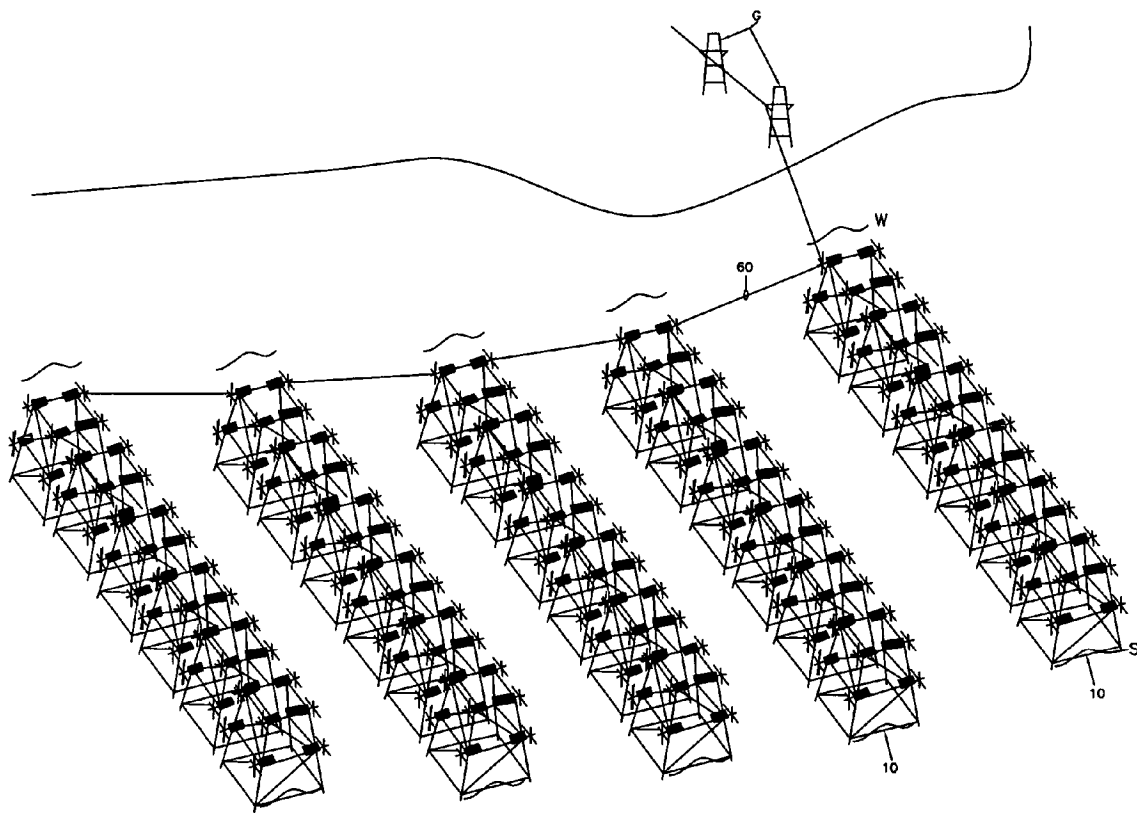

Figure 3

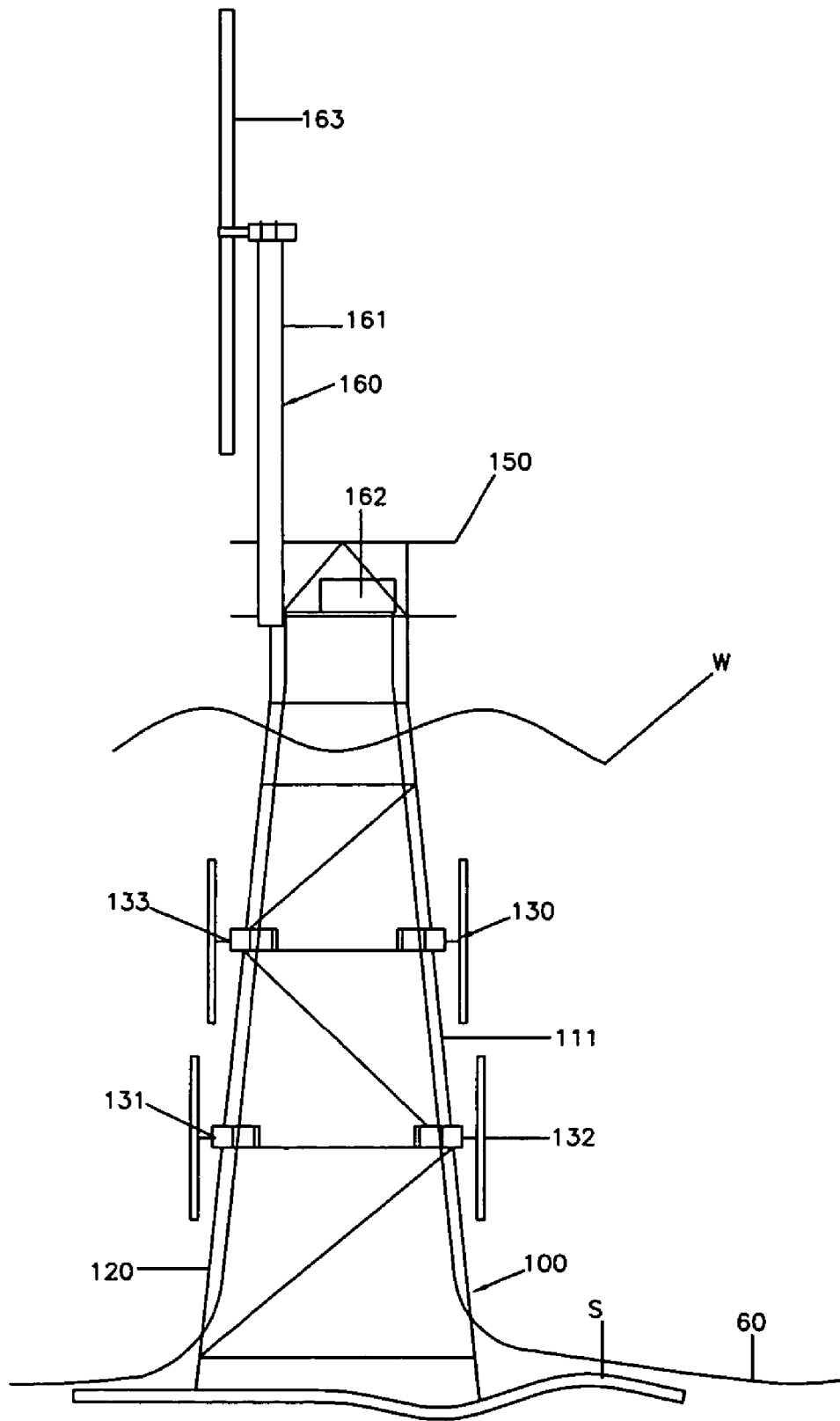

Figure 4

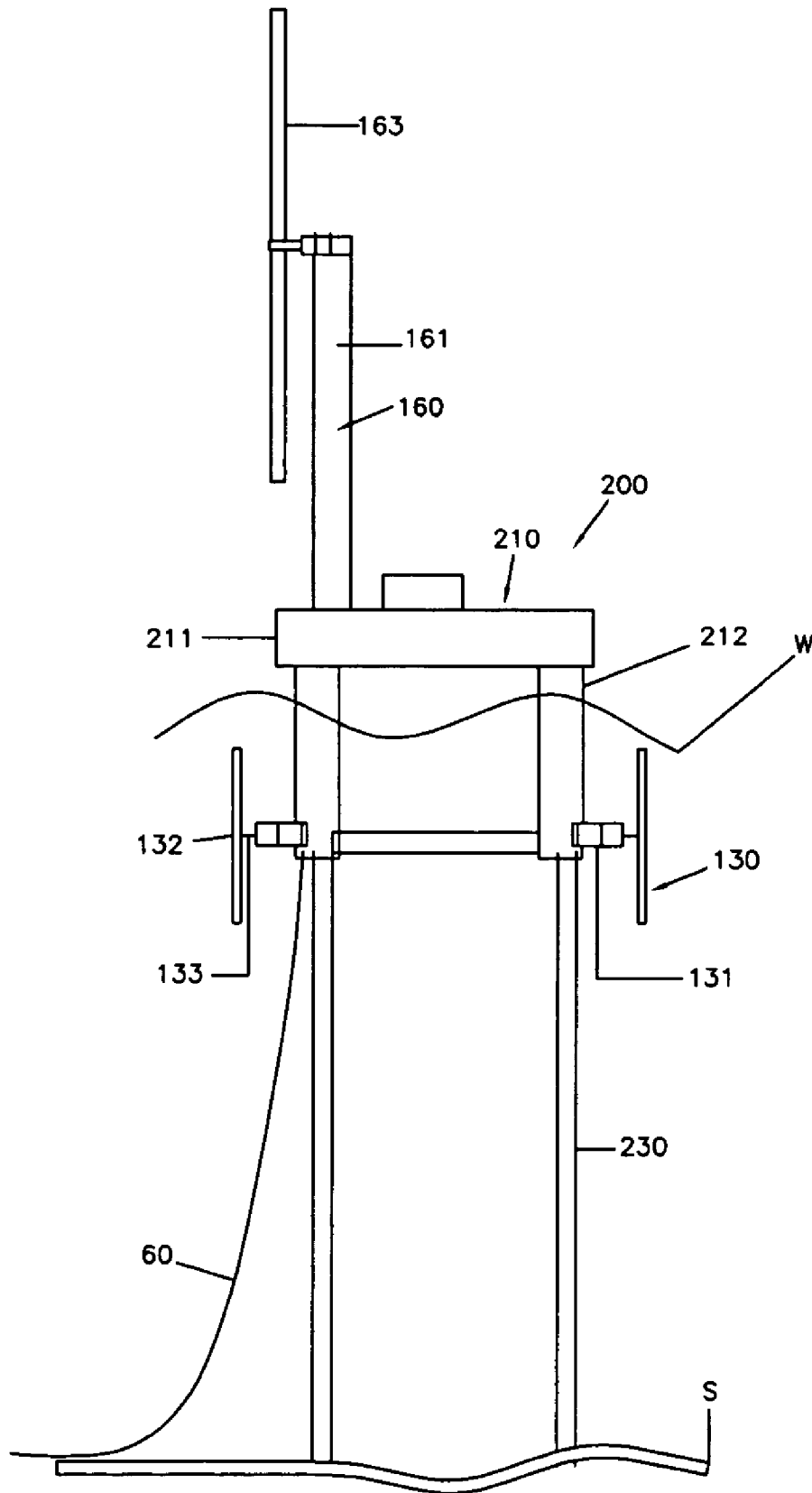

Figure 5

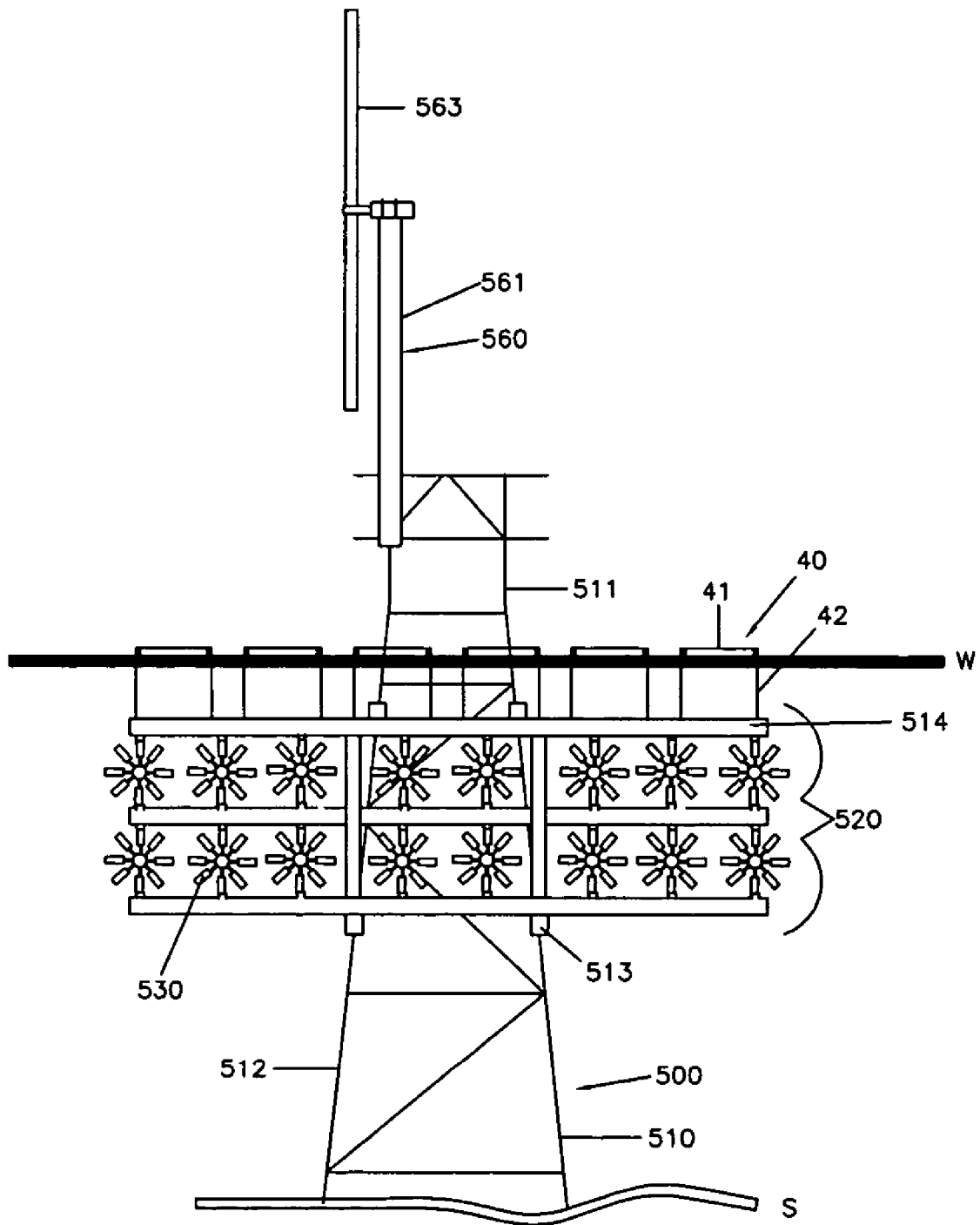

Figure 6

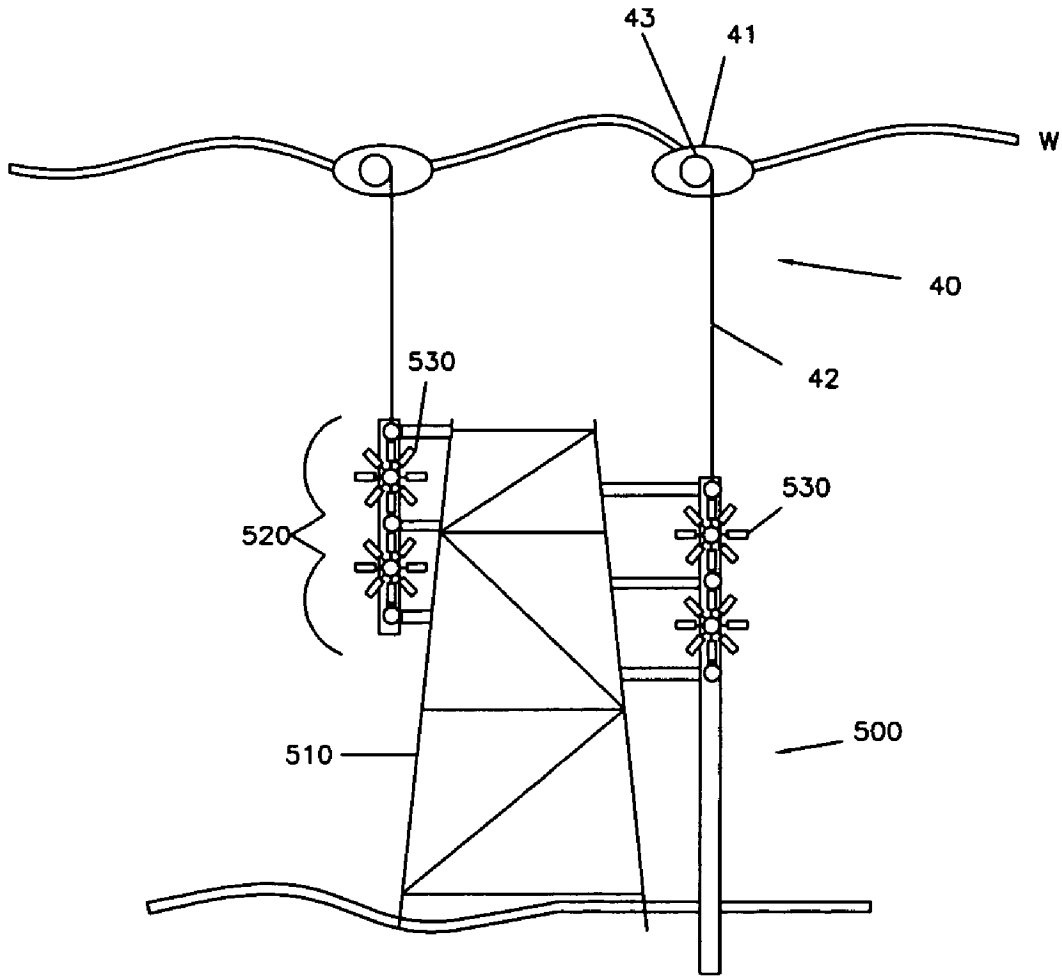

Figure 7



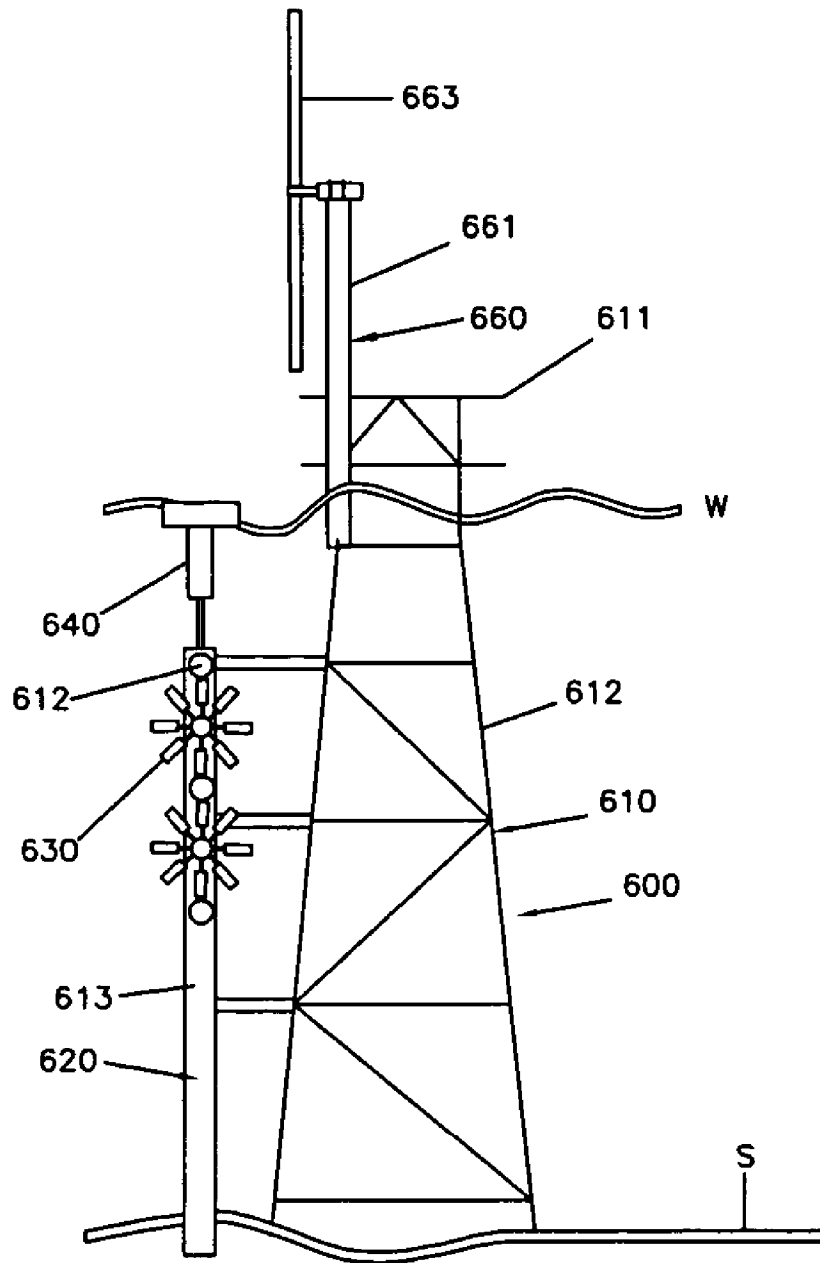

Figure 8

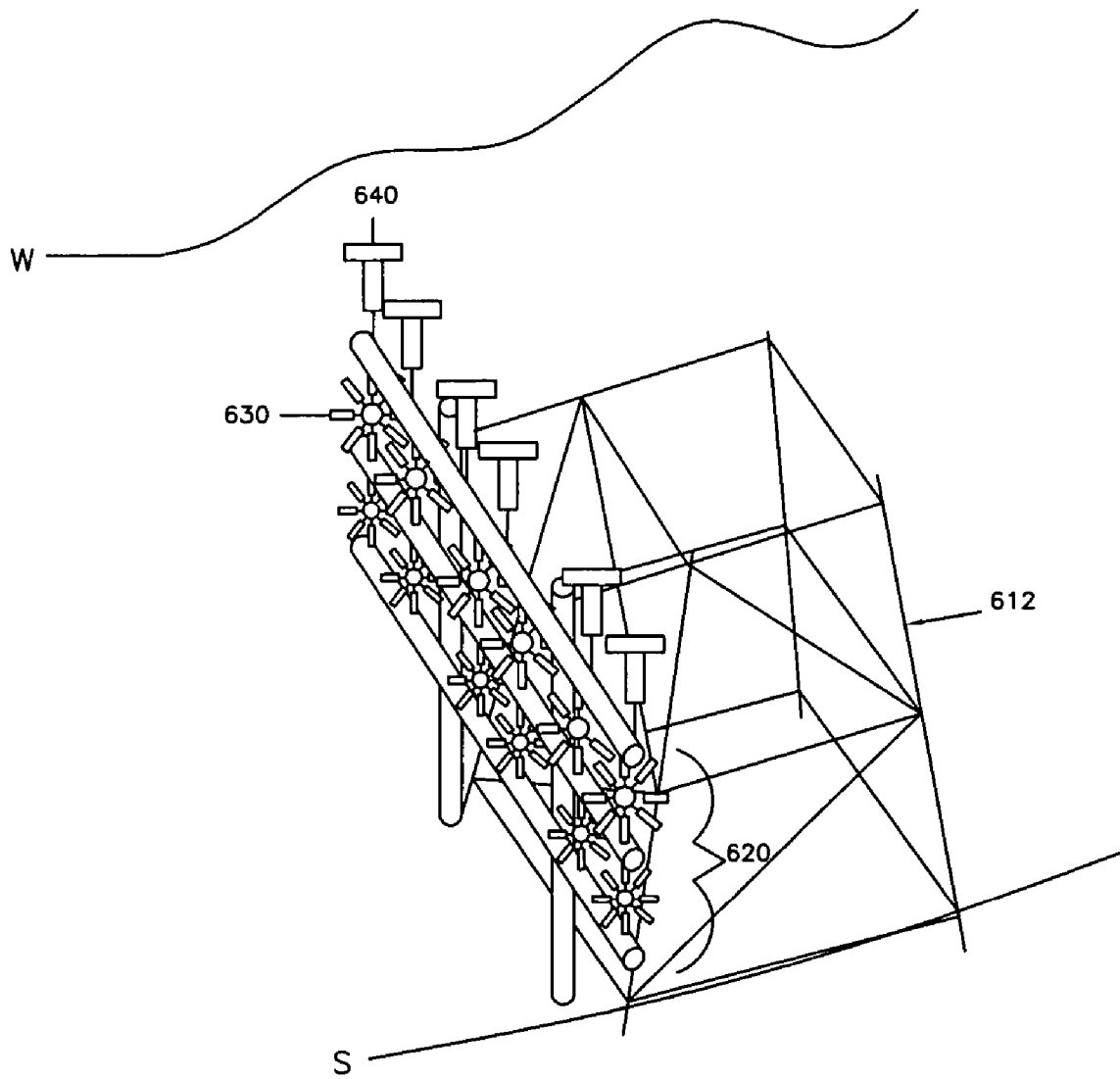

Figure 9

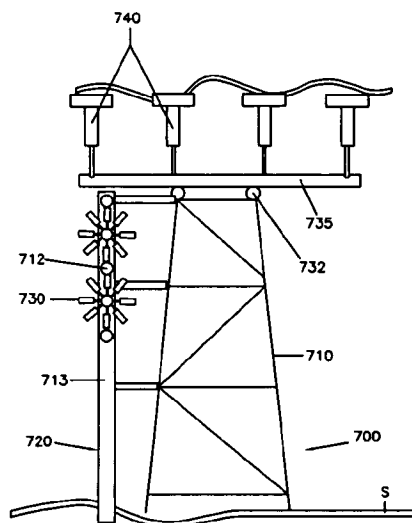

Figure 10a

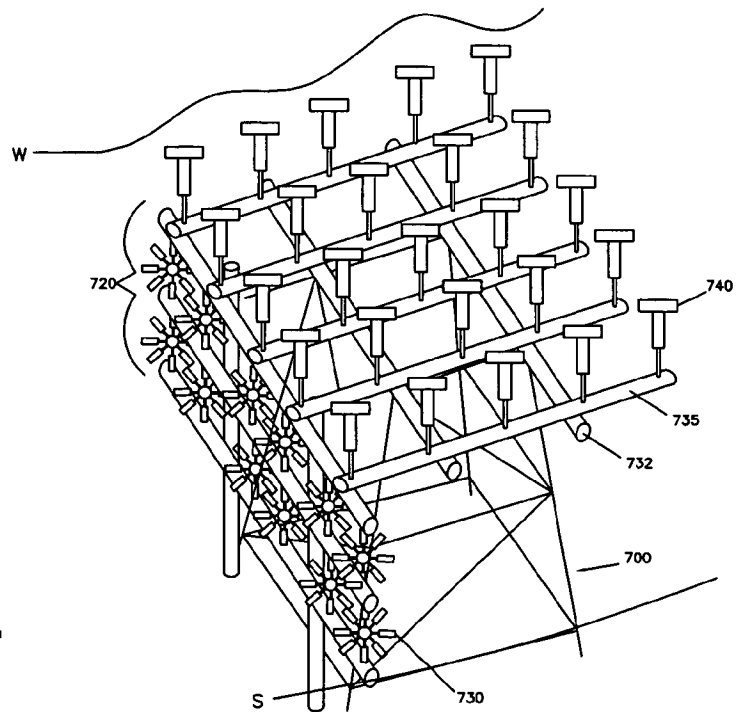

Figure 10b

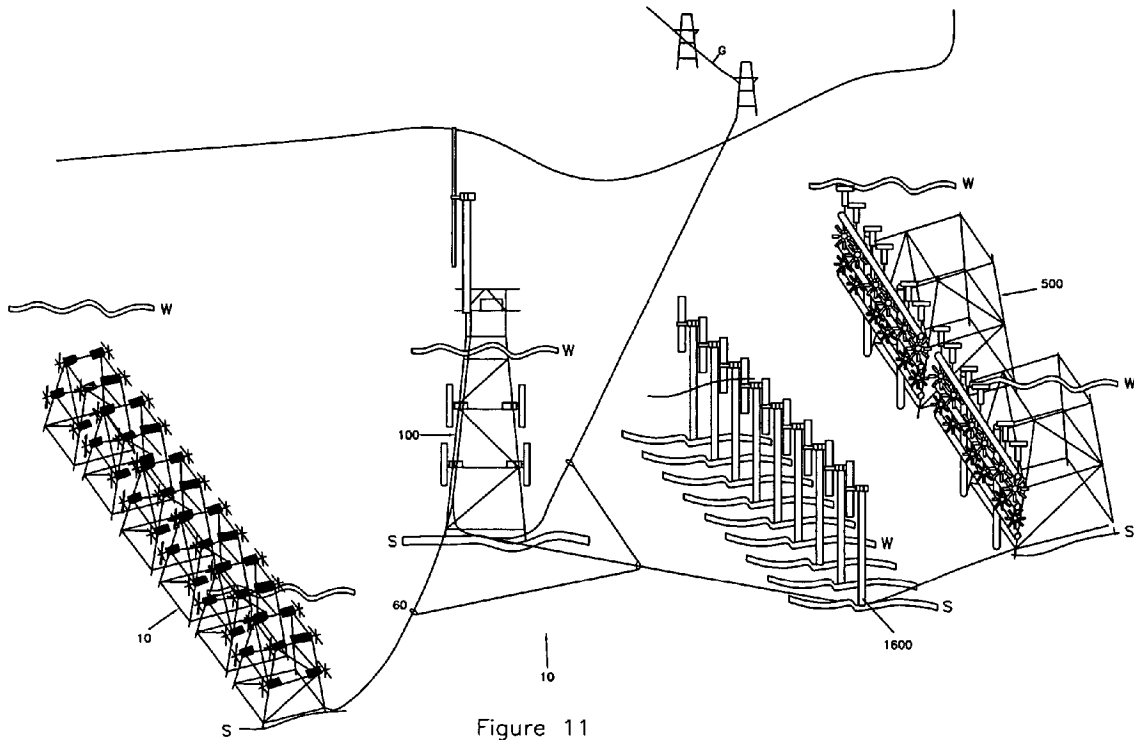

Figure 11

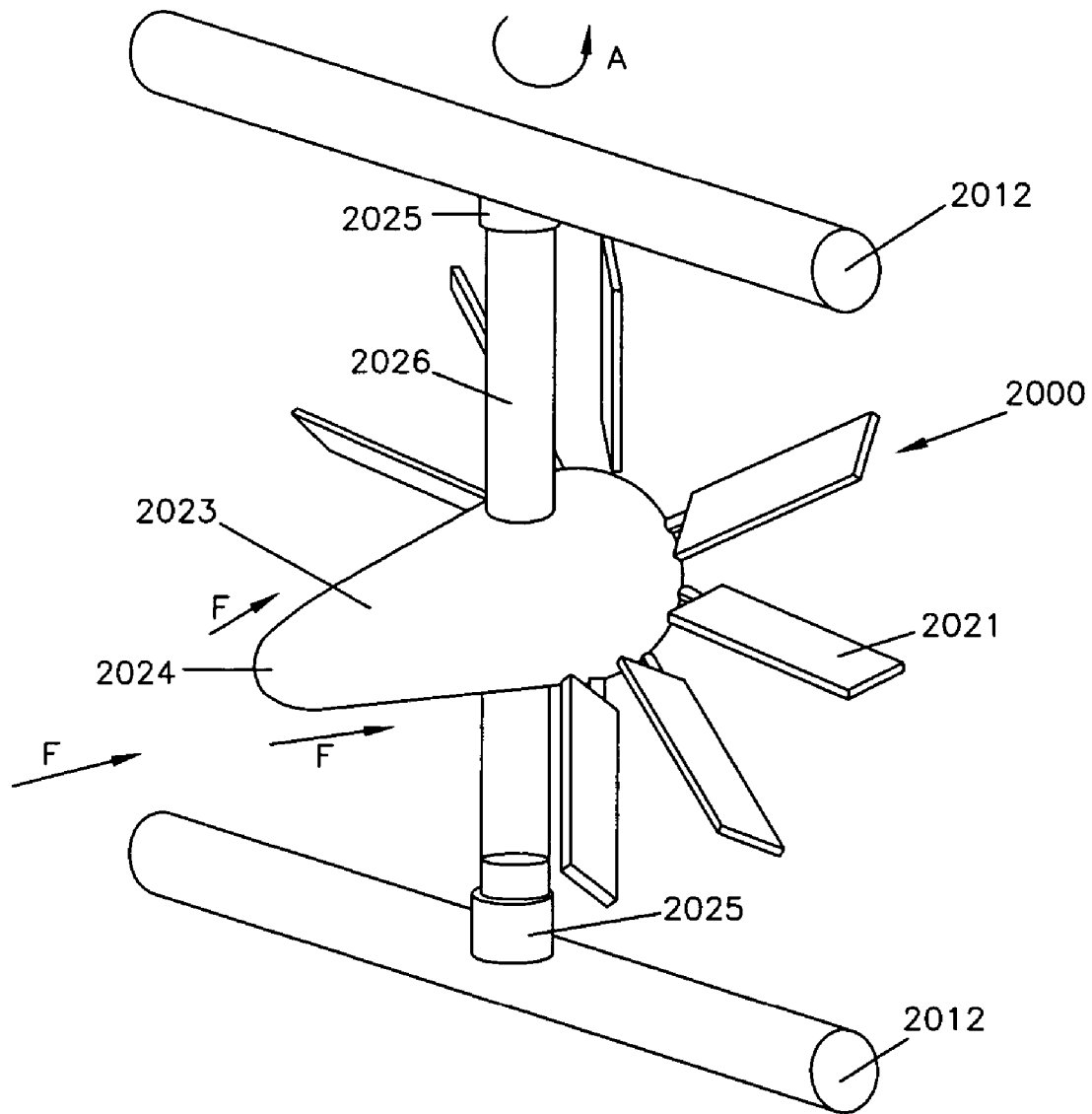

Figure 12

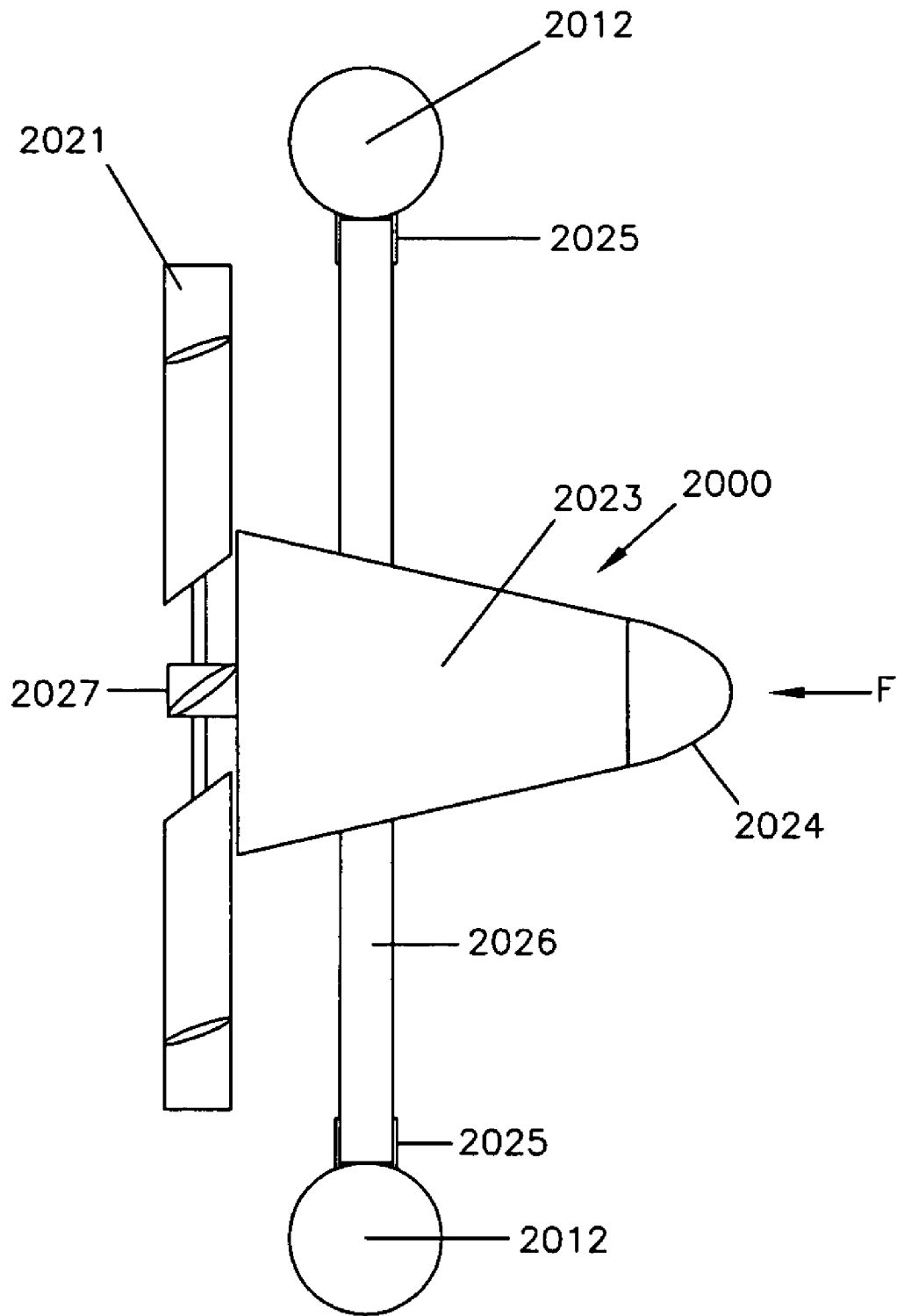

Figure 13

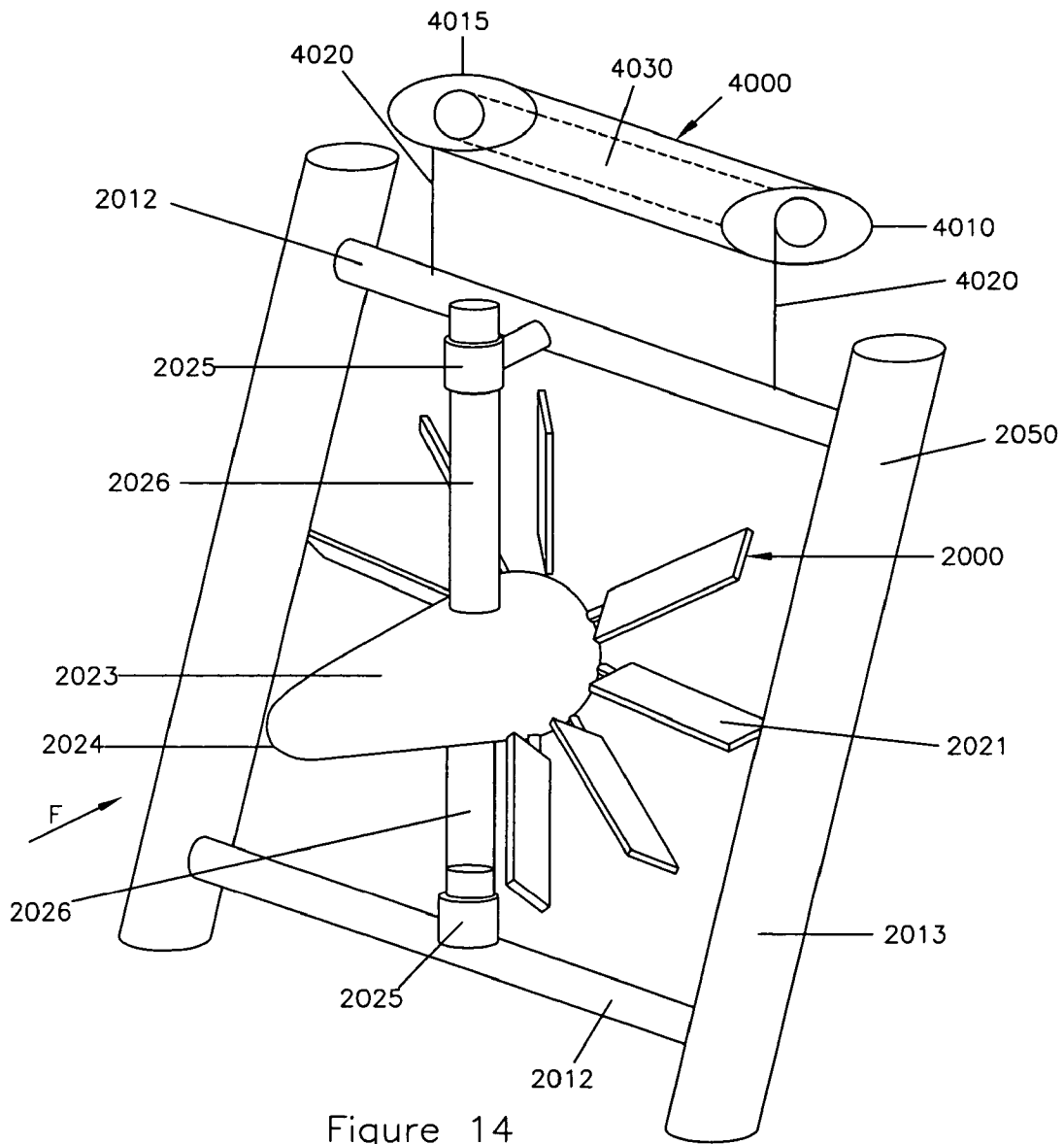
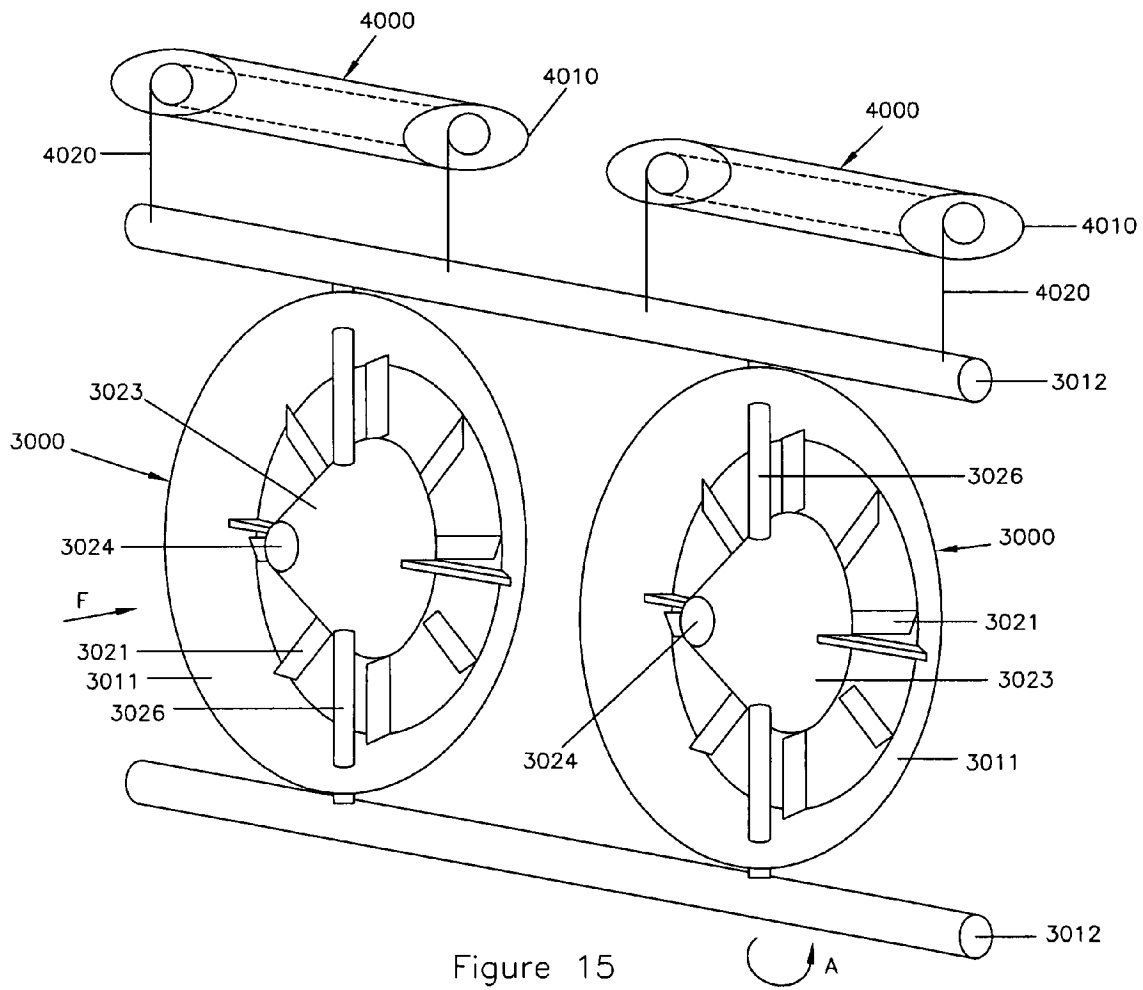

Figure 14





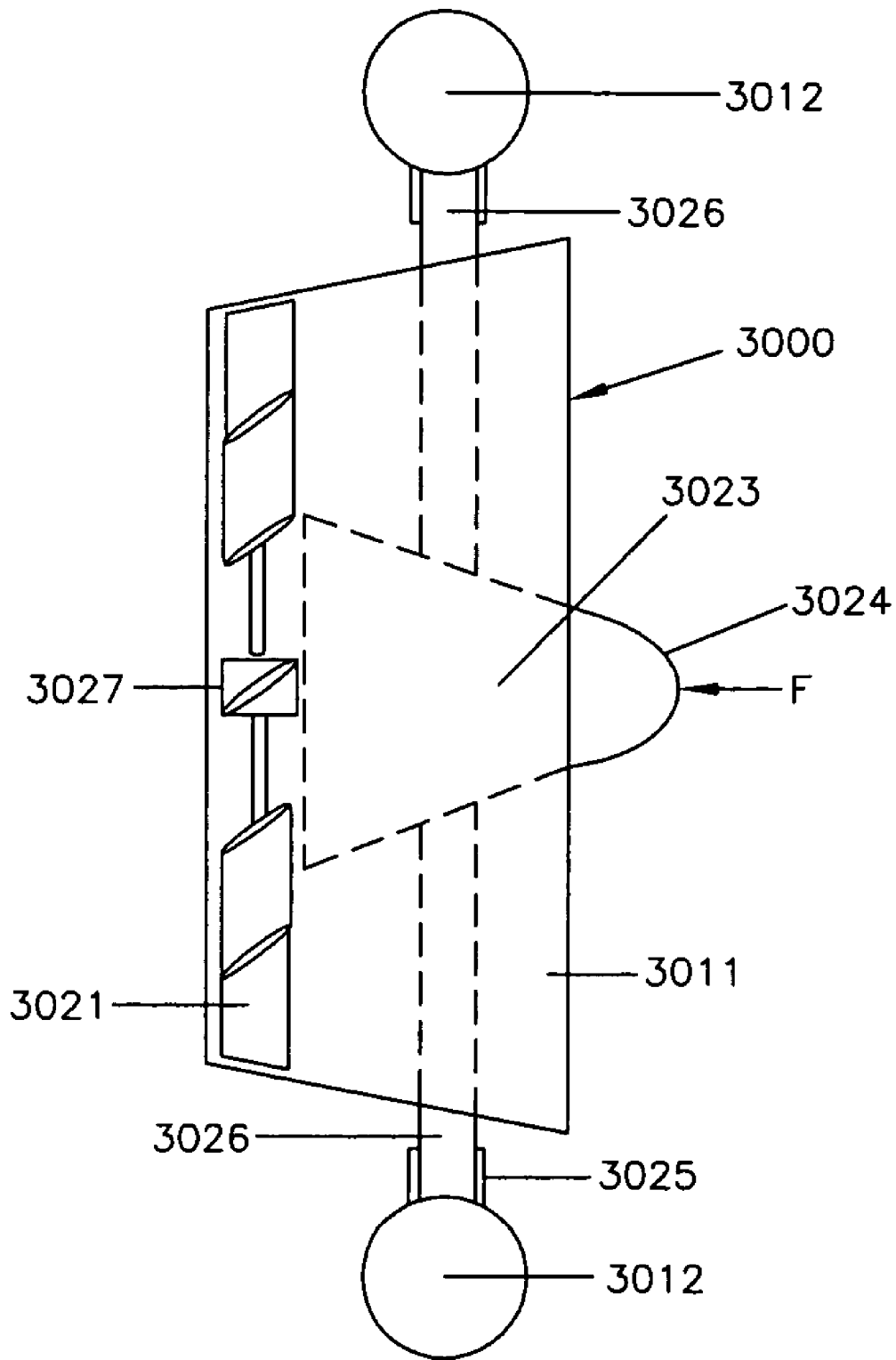

Figure 16

**OFFSHORE POWER GENERATOR WITH  
CURRENT, WAVE OR ALTERNATIVE  
GENERATORS**

CROSS REFERENCED TO RELATED  
APPLICATIONS

This application is a continuation in part of U.S. application Ser. No. 11/132,489 "Current Power Generator" filed on May 19, 2005 which is incorporated herein in its entirety. This application is also a continuation in part of U.S. application Ser. No. 11/142,145 "Ocean Wave Generator" filed Jun. 1, 2005 which is incorporated herein in its entirety.

FIELD OF THE INVENTION

The present invention relates to offshore platforms, and in particular to an offshore power generator using a new, existing, abandoned, removed, dumped or relocated fixed or floating offshore platform.

BACKGROUND OF THE INVENTION

Ordinarily, after an offshore platform has fulfilled its use by extracting all the oil or gas it can from a given location, it is merely discarded. Typically, the platforms are removed to 15 feet below the mudline. Oil companies routinely pay millions of dollars to have the platforms removed and the platforms often become the property of the remover. Many of these platforms are lowered to the seabed in approved dumping sites and are in excellent condition. As a result, the platforms could be re-used for other purposes such as power generation.

U.S. Pat. No. 3,946,568 is directed to an offshore oil production platform comprising one section disposed on the sea bed and another section connected to the one section and projecting up above the sea surface. The one section consists of a plurality of prefabricated units comprising at least one tank divided into a plurality of compartments and having a peripheral wall the thickness of which is not adapted to withstand full water pressure with the tank empty in the submerged state, and at least one compartment in the tank has a peripheral wall the thickness of which is adapted to withstand full water pressure when empty in the submerged state.

U.S. Pat. No. 5,188,484 is directed to a mobile, self-elevating, offshore production platform, for exploitation of smaller reservoirs, with a liquid tight hull having a deck; a plurality of support legs, each having a gear rack and bottom footpads, which are slidably extendable through the hull; a removable jacking tower for each support leg, and, a locking means for each support leg which is engageable to the leg gear rack at any vertical position of the leg. Mineral processing equipment is pre-installed on the deck at a suitable shoreside facility. Then the platform, with legs elevated, is towed to the offshore location where minerals are to be produced. On location the legs are lowered, grounded, and then pre-loaded to desired criteria by introducing ballast water into the hull. After pre-loading the platform is deballasted and elevated to establish a desired air gap. Upon elevation a locking device is engaged to secure each leg in place and the jacking towers, tower powering equipment, and ballast pumps may then be completely removed for storage, or reuse on other platforms. Installation is completed by connecting the hydrocarbon processing equipment to influent and effluent means provided. Upon depletion of the mineral reservoir, or for other reasons such as the threat

of a violent storm, the platform can be removed from one location, and reused at another, by reversing and repeating the above procedure.

U.S. Pat. No. 6,139,224 is directed to a semi-submersible platform for offshore oil operation comprising a buoyant sub-structure comprising a base and a plurality of columns upstanding from said base, a buoyant deck-hull mounted on the columns and means for ballasting and deballasting at least the base of said sub-structure. It further comprises means for tangentially guiding said deck-hull on said columns during deployment of the platform into a predetermined configuration by ballasting of the sub-structure while the deck-hull is floating and means for locking said deck-hull to the columns in said predetermined configuration.

U.S. Pat. No. 5,573,355 is directed to an offshore oil drilling or producing platform comprising a hull carried by legs provided with feet adapted to rest on the sea bed, characterized in that the walls of each of the legs define a space opening onto the respective foot in which are retracted anchoring piles for the leg carried by the foot, each leg being also provided in its upper part with support means in vertical alignment with the piles within the space defined by the walls of the leg for supporting a device for driving the piles into the sea bed.

U.S. Pat. No. 4,025,220 is directed to a fluid-current energy-conversion plant, especially useful for electricity generation, utilizing an axial flow turbine as the energy conversion element, has self-inflated flexible collector elements for capturing a portion of the fluid current, increasing its velocity, guiding at least some of each portion into the turbine's mouth, then returning the captured flow into the stream.

None of the above inventions provide a re-usable offshore oil platform to provide an alternative energy source. It would therefore be beneficial if an alternative energy source utilizing the re-use of decommissioned oil platforms existed to harness energy.

SUMMARY OF THE INVENTION

It is an aspect of the present invention to provide an offshore power generator utilizing a new, existing, abandoned, removed, dumped, or relocated offshore platforms.

It is a further aspect of the present invention to provide an offshore power generator that includes an offshore platform; a support frame mounted to the offshore platform comprising vertical support members and horizontal support members; current generators mounted to the horizontal support members of the support frame; and power cables, in electrical communication with the current generators.

It is yet a further aspect of the present invention to provide an offshore power generator that includes an offshore platform; a support frame mounted to the offshore platform comprising vertical support members and horizontal support members; current generators mounted to the horizontal support members of the support frame; cross support beams mounted to the top of the offshore platform; wave generators mounted to the top of the cross support beams; and power cables, in electrical communication with the current generators and the wave generators.

In accordance with a first aspect of the present invention, a novel offshore power generator is provided. The novel offshore power generator includes an offshore platform; current generators mounted to the offshore platform; and power cables, in electrical communication with the current generators.

3

In accordance with a further aspect of the present invention, an alternative embodiment of a novel offshore power generator is provided. The novel offshore power generator includes an offshore platform; a support frame mounted to the offshore platform comprising vertical support members and horizontal support members; current generators mounted to the horizontal support members of the support frame; and power cables, in electrical communication with the current generators.

In accordance with yet a further aspect of the present invention, a novel offshore power generator is provided including wave generators. The novel offshore power generator includes an offshore platform; a support frame mounted to the offshore platform comprising vertical support members and horizontal support members; current generators mounted to the horizontal support members of the support frame; cross support beams mounted to the top of the offshore platform; wave generators mounted to the top of the cross support beams; and power cables, in electrical communication with the current generators and the wave generators.

#### BRIEF DESCRIPTION OF THE DRAWINGS

The foregoing summary, as well as the following detailed description of a preferred embodiment of the present invention will be better understood when read with reference to the appended drawings, wherein:

FIG. 1 is a perspective view of an offshore power generator in accordance with the present invention.

FIG. 2 is a side elevation view of an offshore power generator in accordance with the present invention including wave generators.

FIG. 3 is a schematic view of a plurality of the offshore power generators of FIG. 1 shown interconnected and to a landside power grid.

FIG. 4 is a side elevation view of an alternative embodiment of an offshore power generator having a surface mounted generator.

FIG. 5 is a side elevation view of a floating offshore power generator.

FIG. 6 is a side elevation view of an alternative embodiment of an offshore power generator.

FIG. 7 is a side elevation view of an alternative embodiment of an offshore power generator in accordance with the present invention.

FIG. 8 is a side elevation of an alternative embodiment of an offshore power generator having an alternative energy generator on a surface platform and wave generators.

FIG. 9 is a perspective view of an alternative embodiment of an offshore power generator having current generators and wave generators in accordance with the present invention.

FIG. 10a is a side elevation view of an offshore power generator of the present invention having a series of wave generators on the top of the generator.

FIG. 10b is a perspective view of the offshore power generator of FIG. 10a.

FIG. 11 is a schematic representation of an ocean generation station.

FIG. 12 is a perspective view of an alternative embodiment of a current generator.

FIG. 13 is a side elevation view of the current generator of FIG. 12.

FIG. 14 is a perspective view of an alternative embodiment of a current generator including an alternative embodiment of a wave generator.

4

FIG. 15 is a perspective view of an alternative embodiment of a current generator having a perimeter cone.

FIG. 16 is a side elevation view of an alternative embodiment of a current generator having a perimeter cone as depicted in FIG. 15.

#### DETAILED DESCRIPTION OF THE PREFERRED EMBODIMENTS

Referring now to the drawings, wherein like reference numerals refer to the same components across the several views and in particular to FIGS. 1, 2, and 3, there is shown an offshore power generator 10. The offshore power generator 10 includes an offshore platform 20 and current generators 30.

The offshore platform 20 rests on the seabed S and has mounted on it a plurality of generators 30. Each current generator 30 in this embodiment of the present invention includes a generator 31, a shaft 33 rotatably mounted within and protruding out of the generator 31, and a plurality of blades 32 mounted to the shaft 33 to turn the shaft 33 in response to water current flow. Electrically connected to the current generators 30 are power cables 60. The power cables 60 transmit the energy generated by the current generators 30 for consumption. For example, the power cables 60 may be connected to a power grid G, located onshore.

Referring now to FIG. 2, the offshore power generator 10 includes an additional wave generator 40 mounted at the top of the offshore platform 20. The wave generators 40 include a buoy 41, an anchor leg 42, and a generator 43 which is operatively connected to the anchor leg 42. When the buoy 41 rises during a wave crest, the anchor leg 42 turns the generator 43 to generate electricity.

FIG. 3 depicts a typical arrangement of a power generation station utilizing a plurality of the offshore power generators 10. The offshore power generators 10 are connected via underwater power cables 60 to one another and can be connected over underwater power cable bridges to an onshore power grid G. The onshore power grid G can transmit the energy generated by the offshore power generators 10 for a variety of uses.

Referring now to FIG. 4, an alternative embodiment of an offshore power generator 100 is depicted. The offshore power generator 100 includes current generators 130 under the surface W of the ocean. The current generators 130 are mounted to an offshore platform 120. Each current generator 130 in this embodiment of the present invention is substantially similar structurally and in operation to the current generators 30. Each current generator 130 is electrically connected to an external control center 162, and in turn to power cables 60. The power cables 60 transmit the energy generated by the current generators 130 and 162 for consumption. For example, the power cables 60 may be connected to the power grid G, located onshore.

The offshore power generator 100 in this embodiment also includes an above the water platform 150. Mounted to the top of the platform 150 is a wind generator 160. The wind generator 160 includes a shaft 161, a generator portion 162, and a windmill 163.

Referring now to FIG. 5, an alternative embodiment of an offshore power generator 200 is depicted. The offshore power generator 200 includes a floating platform 210 having a surface portion 211 and a submerged portion 212. Mounted to the surface portion 211 of the floating platform 210 is the wind generator 160, which includes a shaft 161, and a generator portion 163. In this embodiment, the current generators 130 are mounted to the submerged portion 212 of

5

the offshore power generator **200**. As described in FIG. **1**, the current generators **130** are substantially similar structurally and in operation to the current generators **30**. Each current generator **130** and wind generator **160** are electrically connected to the electrical control center **162**, and in turn to power cables **60**. The power cables **60** transmit the energy generated by the current generators **130** and **160** for consumption. For example, the power cables **60** may be connected to the power grid G, located onshore.

The floating platform **210** is moored to the seabed S by mooring cables **230**. In a preferred embodiment of the present invention, the mooring cables **230** are connected to the submerged portion **212** of the floating platform **210**. However, it is possible that the mooring cables **230** could be connected to the surface portion **211**.

Referring now to FIG. **6**, another embodiment of an offshore power generator **500** is shown. The offshore power generator **500** includes an offshore platform **510**, which has a surface portion **511** and a submerged portion **512**. A current generator frame **520** is mounted to the submerged portion **512** of the offshore power generator **500**. The current generator frame **520** includes vertical support members **513** and horizontal support members **514**. Current generators **530** are mounted to the horizontal support members to generate electricity in response to water current flow. The current generators **530** are substantially similar in structure and operation to the current generators **30** described in FIG. **1**. Mounted to the surface portion **511** of the offshore platform **510** is a wind generator **560**, which includes a shaft **561**, and a windmill **563**. In a preferred embodiment of the present invention, the windmill **563** turns a generator (not shown) in response to air current. Power cables (not shown) can be electrically connected to any combination of the current generators **530**, or wind generators **560**. The current generators **530** and the wind generator **560** generate power independently of each another and transfer power via the power cables for consumption. The wave generators **40** are substantially similar in structure and operation to the wave generators **40** described in FIG. **2**.

Referring now to FIG. **7**, another embodiment of an offshore power generator **500** is shown. The offshore power generator **500** includes an offshore platform **510**, and a current generator frame **520** which is mounted to the offshore platform **510**. The current generator frame **520** includes vertical support members **513** and horizontal support members **514**. Current generators **530** are mounted to the horizontal support members to generate electricity in response to water current flow. The current generators **530** are substantially similar in structure and operation to the current generators **30** described in FIG. **1**. Power cables (not shown) can be electrically connected to the current generators **530** and transfer the power via the power cables for consumption. Since this embodiment has nothing above the water's surface, it has no visual pollution from shore. All components of this embodiment can also be recessed far enough below the water's surface to allow boat traffic above. The wave generators **40** are substantially similar in structure and operation to the wave generators **40** described in FIG. **2**.

Referring now to FIG. **8**, an alternative embodiment of an offshore power generator **600** is depicted. The offshore power generator **600** includes an offshore platform **610**, which has a surface portion **611** and a submerged portion **612**. The offshore platform **610** is mounted to the seabed S. A current generator frame **620** is mounted to the submerged portion **612** of the offshore power generator **600**. The current generator frame **620** includes vertical support members **613** and horizontal support members **612**. Current generators **630** are mounted to the horizontal support members to generate electricity in response to water current flow. The current generators **630** are substantially similar in structure

6

and operation to the current generators **30** described in FIG. **1**. Mounted to the surface portion **611** of the floating platform **610** is a wind generator **660**, which includes a shaft **661**, and a windmill **663**. In a preferred embodiment of the present invention, the windmill **663** turns a generator (not shown) in response to air current. Wave generators **640** are mounted to the topmost horizontal support member **612** of the support frame **620** to generate electricity from the rising and falling of waves. The wave generators **640** are substantially similar in structure and operation to the wave generators **40** described in FIG. **2**. Power cables (not shown) can be electrically connected to any combination of the current generators **630**, the wave generators **640**, or the wind generator **660**. For example, the current generators **630**, wave generators **640**, and the wind generator **660** can generate power independently of one another or in any combination with one another to be transferred via the power cables for consumption.

FIG. **9** depicts an alternative embodiment of the offshore power generator with only the top of the wave generator above the water's surface W, minimizing visual pollution.

FIGS. **10a** and **10b** depict an alternative embodiment of an offshore power generator **700**. The offshore power generator **700** is substantially similar to the submerged portion of the offshore power generator **600** of FIG. **9**. The offshore power generator **700** includes an offshore oil platform **710** mounted to the seabed S and submerged beneath the surface of the water. A support frame **720** is mounted to the offshore platform **710** and includes vertical support members **713** mounted to the seabed S and horizontal support members **712**. In a preferred embodiment of the present invention, the horizontal support members **712** are mounted generally perpendicularly to the vertical support members **713**, however, the horizontal support members **712** may be attached in any way known to one of ordinary skill in the art. Current generators **720** are mounted to the horizontal support members **712** to generate electricity from water current. The current generators **730** are substantially structurally similar to, and operate substantially similarly to the current generators **30**. Mounted to the top of the topmost portion of the offshore platform are horizontal support members **732** with a series of cross support beams **735** upon which wave generators **740** are mounted. The wave generators **740** are substantially structurally similar to, and operate substantially similarly to the wave generators **40**. Power cables (not shown) can be electrically connected to the current generators **730**, and to the wave generators **740** to transfer the electrical energy from the current generators **730** and the wave generators **740** for consumption, for example, via a power grid (not shown). In a preferred embodiment of the present invention, the wave generators **740** generate electricity independent of the current generators **730**.

FIG. **11** represents a typical arrangement of offshore power generators such as **10**, **100**, and **500** all interconnected to the power cables **60** and to the power grid G onshore. In addition to the offshore power generators, alternative energy generators **1600** may be added to the arrangement to provide additional energy production along side the offshore power generators. In a preferred embodiment of the present invention, the alternative energy generators **1600** are wind power generators, however, any alternative energy generators known to one of ordinary skill in the art may be used. Furthermore, although only offshore power generator embodiments **10**, **100**, and **500** are depicted in FIG. **11**, any combination of any of the embodiments of the offshore power generators may be used.

FIGS. **12** and **13** depict an alternative embodiment of a current generator **2000**. The current generator **2000** includes

blades 2021 mounted to a shaft 2027. The current generator, in a preferred embodiment, is mounted to a horizontal support frame 2012.

When the blades 2021 are rotated by the current flow F, the blades 2021 turn the shaft 2027 which generates power. An extension shaft 2026 is mounted to the generator 2000 and proceeds generally perpendicularly outward there-through. The extension shaft 2026 is attached to the horizontal support frame 2012. Disposed on the extension shaft 2026 proximate the horizontal support frame 2012 are electrical contactors 2025. The electrical contactors 2025 are electrically connected to power cables 60 to transfer the electricity generated by the generators 2000 to a power grid (not shown). The generator 2000 is pivotally mounted to the extension shaft 2026 so as to allow the generator 2000 to pivot about its axis in the direction of the arc A, or in the opposite direction to arc A.

A cone 2023 is disposed around the shaft 2027 of the generator 2000 to direct current flow F onto the blades 2021. The cone 2023 includes a nose section 2024 to direct current flow F outward toward the blades 2021. In a preferred embodiment of the present invention, the cone 2023 responds to current flow F in order to align with the current flow F, similar to a weathervane. As the cone 2023 weathervanes to align with the current flow F, the shaft 2026 causes the generator 2000 to pivot about its axis. Furthermore, the current flow F causes the plurality of blades 2021 to rotate the shaft 2027, which in turn operates the generator 2000 to generate electricity.

FIG. 14 depicts an alternative arrangement of the current generator 2000 that includes the addition of a wave generator 4000. The current generator 2000 and the wave generator are mounted to a frame 2050, which includes vertical support members 2013 and the horizontal support members 2012 disposed substantially perpendicularly to the vertical support members 2013.

The wave generator 4000 includes a buoy 4010, a pair of anchor cables 4020, a generator 4030, and a pair of pulleys 4015 disposed at either end of the buoy 4010.

The buoy 4010 floats on the surface of the ocean and rises and falls as the waves rise and fall. The anchor cables 4020 are connected to the pulley 4015 at one end and to the uppermost horizontal support member 2012 of the support frame 2050. The generator 4030 is operatively attached to the pulleys 4015 and turns when the pulleys 4015 turn to generate electricity.

FIGS. 15 and 16 depict an alternative embodiment of a current generator 3000. The current generator 3000 includes blades 3021 mounted to a shaft 3027. The current generator 3000, in a preferred embodiment, is mounted to a horizontal support frame 3012.

When the blades 3021 are rotated by the current flow F, the blades 3021 turn the shaft 3027 which generates power. An extension shaft 2026 is mounted to the generator 3000 and proceeds generally perpendicularly outward there-through. The extension shaft 3026 is attached to the horizontal support frame 3012. Disposed on the extension shaft 3026 proximate the horizontal support frame 3012 are electrical contactors 3025. The electrical contactors 3025 are electrically connected to power cables to transfer the electricity generated by the generators 3000 to a power grid (not shown). The generator 3000 is pivotally mounted to the extension shaft 3026 so as to allow the generator 3000 to pivot about its axis in the direction of the arc A, or in the opposite direction to arc A.

A cone 3023 is disposed around the shaft 3027 of the generator 3000 to direct current flow F onto the blades 3021. Cone 3023 comprises a hub with a downstream end at blades

3021. The cone 3023 includes an upstream nose section 3024 to direct current flow F outward toward the blades 3021. In a preferred embodiment of the present invention, the cone 3023 responds to current flow F in order to align with the current flow F, similar to a weathervane. As the cone 3023 weathervanes to align with the current flow F, the shaft 3026 causes the generator 3000 to pivot about its axis. Furthermore, the current flow F causes the plurality of blades 3021 to rotate the shaft 3027, which in turn operates the generator 3000 to generate electricity.

A shroud 3011 is disposed upon the extension shaft 3026 and proceeds substantially circumferentially around the blades 3021. The shroud 3011 diverts current flow F on the outer edges of the blades 3021 toward the blades 3021. A plurality of wave generators 4000 may be mounted to the uppermost horizontal support member 3012.

In a preferred embodiment of the present invention, the wave generators and their components described herein are substantially similar to the wave generators described in U.S. patent application "Ocean Wave Generator" having a Ser. No. 11/142,145 filed Jun. 1, 2005 by Donald H. Gehring, which is incorporated herein in its entirety. Similarly, the current generators, and their components described herein are substantially similar to the current generators described in U.S. patent application "Current Power Generator" having a Ser. No. 11/132,489 filed on May 19, 2005 by Donald H. Gehring and incorporated herein in its entirety.

In view of the foregoing disclosure, some advantages of the present invention can be seen. For example, a novel offshore power generator is provided. The novel offshore power generator utilizes new, existing, abandoned, removed, dumped or relocated fixed or floating offshore platforms as energy generators.

While the preferred embodiment of the present invention has been described and illustrated, modifications may be made by one of ordinary skill in the art without departing from the scope and spirit of the invention as defined in the appended claims.

What is claimed is:

1. A current generator, comprising:

- a support frame;
- a generator mounted to the support frame, including a rotatable shaft, operatively connected to the generator such that when the shaft rotates, the generator generates electricity;
- a plurality of blades mounted to the rotatable shaft, capable of rotation in response to water current;
- an extension shaft, mounted to the generator and pivotally mounted to the support frame;
- a cone disposed upon the generator generally axially about the shaft to direct current flow to the outer edges of the plurality of blades;
- a power cable in electrical communication with the generator; and
- a wave generator mounted to the support frame, said wave generator comprising a buoy, a pair of pulleys disposed at either end of the buoy operatively connected to a generator disposed within the buoy, a pair of anchor cables mounted at one end to the support frame and at the other end to the pulleys to turn the pulleys, which in turn rotate the generator to generate electricity.

2. The current generator of claim 1, further comprising a shroud, mounted to the extension shaft and disposed substantially circumferentially about the outer edges of the plurality of blades.